

# APPENDIX 1



**Monmouthshire County Council  
Local Development Plan**

## **Draft Supplementary Planning Guidance**

### **Infill Development**

**(Policies H1, H2 and H3)**

**March 2019**

**Planning Policy Service  
Monmouthshire County Council**  
County Hall  
The Rhadyr  
Usk  
NP15 1GA

**Tel. 01633 644429**

**Email: [planningpolicy@monmouthshire.gov.uk](mailto:planningpolicy@monmouthshire.gov.uk)**

# CONTENTS

	<b>Page</b>
1. Introduction: Purpose of the Supplementary Planning Guidance	1
2. The Starting Point	2
3. The Initial Stage – Site Appraisal	4
4. Infill Development Proposals – Detailed Considerations	5
A – Site Context	6
B – Design	7
C – Privacy/Amenity	9
D – Sustainable Transport/Access/Parking	12
E – Planting/Trees	14
F – Drainage	15
G – Planning Contributions	16
5. Pre-Application Advice and Further Information	17
<b>Appendix A: LDP Policy Framework – Policies S1, H1, H2 and H3</b>	<b>18</b>

# 1 Introduction: Purpose of this Supplementary Planning Guidance

## Introduction

- 1.1 This is one of a series of Supplementary Planning Guidance (SPG) documents that have been prepared to provide supporting information and advice on policies contained in the adopted Monmouthshire Local Development Plan (LDP). The SPGs are intended to offer further guidance on the main considerations that will be taken into account by the Council when reaching decisions on planning applications and in this case how planning policy on infill development will be implemented in practice.
- 1.2 This SPG provides guidance on small scale (fewer than 10 dwellings) infill development within the designated settlements as defined under Policies S1, H1, H2 and H3 of the Monmouthshire LDP i.e. the Main Towns, Severnside Settlements, Rural Secondary Settlements, Main Villages and Minor Villages (refer to Appendix 1 for details of the relevant policy framework).
- 1.3 The overarching objectives for infill development as set out in this SPG are to:
- Make efficient use of brownfield land.
  - Protect residential amenity, both of new and existing occupiers.
  - Make a positive contribution to the creation of distinctive communities, places and spaces.
  - Respond to the context and character of the area.
  - Be of a good design, which is sustainable.

### Box 1: Definition of Small Scale Infill Development

There are generally two main types of infill development:

- **Infill sites** - are normally regarded as small gaps between existing residential properties, usually with a street frontage

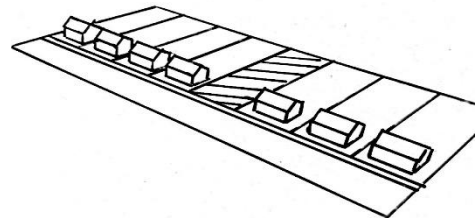

- **Backland sites** - can be a landlocked site, which may have a considerable number of 'inactive' frontages surrounding the site boundary (i.e. fences or walls). They may also be located behind existing buildings such as rear gardens and private open space, usually within predominantly residential areas.

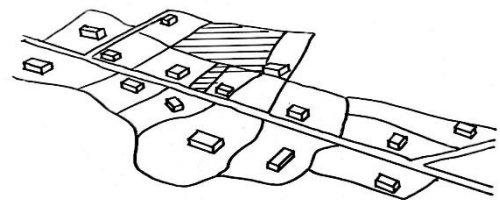

## 2 The Starting Point

### **The first step is to check if your proposal is acceptable in principle**

- 2.1 In determining whether your infill site proposal is acceptable in principle, the first point to consider is whether your site is within a settlement boundary as defined in Strategic Policy S1 of the LDP. Development boundaries have been drawn around the Main Towns, Severnside Settlements, Rural Secondary Settlements and Main Villages. Minor Villages do not have development boundaries. You are able to check our interactive LDP maps to see if your land is within one of the settlements as designated in Policies S1, H1, H2 and H3 of the LDP: <https://www.monmouthshire.gov.uk/planning>
- 2.2 The Monmouthshire LDP aims to achieve an appropriate level of housing growth and choice to assist in building sustainable communities in Monmouthshire's most sustainable settlements while strictly controlling new development in the open countryside. These settlements are identified in Table 1. In accordance with

Policy H3, please note that in Minor Villages planning permission will only be granted for minor infill development of no more than 1 or 2 dwellings resulting from the filling in of a small gap between existing dwellings. Only in exceptional circumstances may an infill development of up to 4 dwellings be considered acceptable in Minor Villages.

- 2.2 For Minor Villages, we would normally define the settlement by looking at the existing physical features such as field boundaries, roads, trees, rivers, and railway lines; generally the edge closest to village.
- 2.3 Some Minor Villages comprise of two or more separate populated clusters. Infill development will not normally be appropriate in such areas. If in doubt, discuss your proposal with one of the planning officers via our Pre-application Enquiry Services (see section 5 of this SPG).

### **Box 2: C2 Floodplain**

Please note, if your land is within Zone C2 Floodplain Welsh Government advice is that no highly vulnerable development should be considered. Housing falls into this category. For more information on this please refer to Technical Advice Note 15 (TAN15) which provides Welsh Government's guidance on development and flood risk: <https://gov.wales/topics/planning/policy/tans/tan15/?lang=en>

**Table 1: Settlements Defined in Strategic Policy S1**

<b>Main Towns</b>	Abergavenny	Chepstow	Monmouth
<b>Severnside Settlements</b>	Caerwent	Caldicot	Magor/Undy
	Portskewett	Rogiet	Sudbrook
<b>Rural Secondary Settlements</b>	Penperlleni	Llanfoist	Raglan
	Usk		
<b>Main Villages</b>	Cross Ash	Devauden	Dingestow
	Grosmont	Little Mill	Llanddewi Rhydderch
	Llandogo	Llanellen	Llangybi
	Llanishen	Llanvair Kilgeddin	Mathern
	Penallt	Pwllmeyric	Shirenewton /Mynyddbach
	St Arvans	Trellech	Werngifford /Pandy
<b>Minor Villages</b>	Bettws Newydd	Broadstone/Catbrook	Brynygwenin
	Coed-y-Paen	Crick	Cuckoo's Row
	Great Oak	Gwehelog	Llanarth
	Llandegveth	Llandenny	Llangwm
	Llanover	Llansoy	Llantilio Crossenny
	Llantrisant	Llanvair Discoed	Llanvapley
	Mitchel Troy	Penpergwm	The Narth
	The Bryn	Tintern	Tredunnoch

### 3 The Initial Stage – Site Appraisal

3.1 There are other matters that must be considered in determining whether a proposal for infill development would be acceptable. A Site Appraisal will allow you to understand how the proposal relates to its immediate context and wider area, as well as helping you to develop a scheme which uses your site's positive features and to identify features worthy of retention. Welsh Government Technical Advice Note (TAN) 12: Design (2016) provides detailed design advice and should be referred to accordingly.

3.2 A Site Appraisal should be undertaken before the details of a scheme is drawn up. The level of detail that will be necessary for a Site Appraisal will vary depending on the scale of the proposal and the characteristics of the site. Table 2 sets out some of the key considerations that you will need to consider in undertaking a Site Appraisal.

3.3 It is strongly recommended that specialist professional planning advice is sought where proposals depend on accurate information relating to issues such as flooding, site levels, ground conditions, ecology, transportation etc. **Getting the right advice at an early stages of your scheme is very important and will help steer you in the right direction from the start of the process.** This is where the Council's Pre-Application Advice service can help. We welcome and encourage discussions with homeowners or developers before they submit a planning application. This service gives you the opportunity to explore your scheme with us and find out what information you need to support your planning application. Please

refer to Section 10 of this Guidance for more information about this service.

3.4 The use of additional annotated diagrams and scaled plans (e.g. 1:100, 1:200) as part of the Site Appraisal can often help to demonstrate how the proposal will impact on the appearance and character of the area.

**Table 2: Key Matters to be Considered When Undertaking a Site Appraisal.**

- 
- Flood risk assessment
  - Habitat and or protected species surveys
  - Tree surveys
  - Drainage
  - Archaeological surveys
  - Adjoining land uses
  - Settlement form and street patterns
  - Existing landscape features
  - Views into, from and across the site
  - Spaciousness and extent of open space
  - Topography, gradient and orientation
  - Plot and building sizes
  - Landmarks, historic buildings, historic parks and gardens, local vernacular architecture and/or landscape
  - Identify any public right of ways, parks and green spaces
  - Accessibility
  - Traffic surveys
  - Potential accesses and linkages
  - Noise assessment/proximity to nuisance causing operations
- 

3.5 Please note that consideration of the matters in Table 2 will depend on the scale of the proposal. For example, flood risk assessments, species surveys and traffic surveys are unlikely to be necessary for all proposals. If in doubt, it is important to seek further advice from the Planning Team via the Pre-Application Advice Service.

## 4 Infill Development Proposals – Detailed Considerations

4.1 This section sets out the key considerations that the Council will consider when assessing proposals for small scale infill development.

### **Is your land large enough to accommodate additional development?**

4.2 Once you have carried out a Site Appraisal, you then need to work out if your land is large enough to accommodate an additional house(s) whilst also providing sufficient on-site parking/turning provision and garden space that is similar to existing houses in the area.

### **Detailed Considerations**

4.3 You then need to consider whether or not your scheme would meet the Detailed Considerations A – G as set out in this section of the SPG. Please note that every site is different. Therefore, it is not possible to cover every scenario in this SPG. However, as a starting point, this section of the SPG sets out the detailed considerations that you need to take into account when considering proposals for small scale infill development..

**Table 3: Detailed Considerations for Small Scale Infill Development**

	<b>Detailed Considerations</b>
<b>A</b>	Site Context
<b>B</b>	Design
<b>C</b>	Privacy/Amenity
<b>D</b>	Access/Parking
<b>E</b>	Planting/Trees
<b>F</b>	Drainage
<b>G</b>	Planning Contributions

## Detailed Consideration A – Site Context

### Plot Size

- 5.1 Plot size ratios should reflect those prevailing in adjacent properties i.e. where there is a regular plot size and width, you should reflect these into your proposal, so that the proposal fits well with the street scene and provides similar visual separation where appropriate.

### Garden

- 5.2 The garden has as much of an impact on the character of an area as the form and design of the buildings. For example, a house with a large garden could appear incongruous within a high density residential area, and vice versa. All new dwellings should benefit from private garden space, for drying clothes, accommodating pets, children's play, quiet enjoyment and so on. Therefore, all residential development should ensure that the garden space reflects the size and function of the proposed dwelling(s) and the prevailing character of the area; these standards also apply to the host dwelling. It should be noted that front gardens do not normally constitute private garden space but often make an important contribution to the character of the area.

### Orientation

- 5.3 All proposed houses and gardens should be laid out so as to maximize the penetration of sunlight i.e. by having the orientation of the garden and the windows of the main rooms facing the south.

**Sketch 1** below shows an example where the plot size of the infill proposal does not reflect the prevailing character of the adjacent properties in terms of scale, mass and rhythm of the street scene. Such a proposal would not be acceptable.

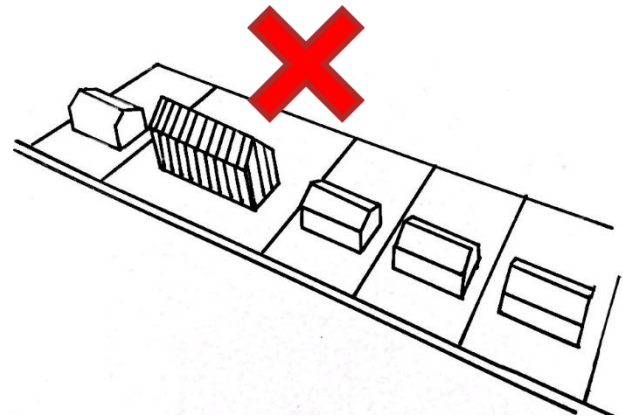

**Sketch 2** below shows a good example of how the land should be divided reflecting the prevailing character of the adjacent properties.

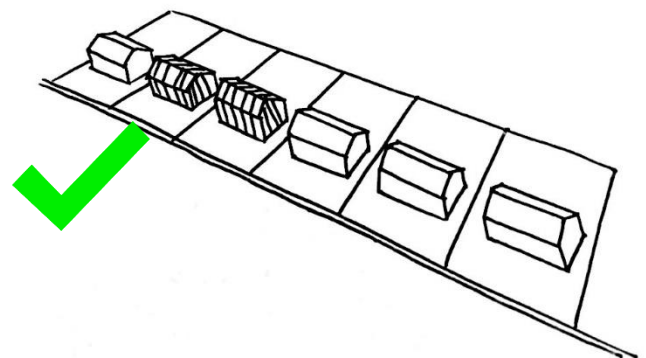



## Detailed Consideration B – Design

### Scale and Massing

- 6.1 The proposal must respect the scale, form and massing of existing development in the area. In most cases, there is an expectation that the massing of the proposal should be in proportion to the main property and the existing neighbouring buildings, as appropriate. However, in designated areas i.e. in the Wye Valley Area of Outstanding Natural Beauty, a Conservation Area or within the curtilage of a Listed Building, all proposals must be subservient and respect the setting of the site area.

### Building Height

- 6.2 Development for infill sites should take account of and respond to existing building heights in the area (number of storeys and floor to ceiling heights), maintaining the visual character of the street scene. For backland sites, a less conspicuous building of a lower scale in building height is often more appropriate to avoid the development having an overbearing impact on neighbours and to reduce impact on residential amenity.

### Topography of the Site

- 6.3 Account should also be taken of the topography of the site to maintain the building height hierarchy along the street scene.

### Building Line

- 6.4 For infill sites, the development should seek to respond to the prevailing building line that is created by the main frontages of

neighbouring houses i.e. any development proposals need to take into account how the buildings are set back from the street and any rhythms or patterns of existing development, or projections. For Backland sites and sites where there is no prevailing building line, all proposals must demonstrate that there will be no adverse privacy and amenity impact upon the existing properties.

**Sketch 3** below shows an unacceptable form of infill development (Building height, Scale and Massing and Building line).

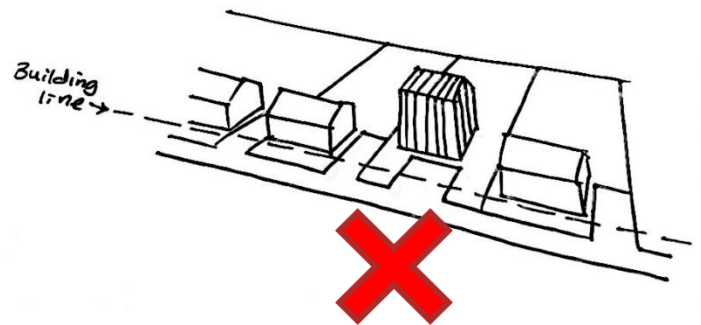

### Box 3: Heritage Assets

The Council will consider proposals for small scale infill development with special care, particularly those in or adjoining Conservation Areas and near Listed Buildings, Scheduled Ancient Monuments, in or adjoining the Wye Valley Area of Outstanding Natural Beauty and adjoining the Brecon Beacons National Park. All development proposals are required to either preserve or enhance the special character of these areas. Within these protected areas, you are normally required to submit a Full Planning Application to enable us to fully assess the implications of your proposals.

## Architectural Detailing

- 6.5 All proposed new window and door openings should complement the size, proportions, design and rhythm of the detailing of the host dwelling and the neighbouring properties appropriately. The roofline should include appropriate design and pitch of roofs, ridge height and eaves level, and notice should be taken of any other relevant details in the street scene.

## Building Materials

- 6.6 The predominant facing materials of the proposal should reflect the materials of the host dwelling and, where appropriate, the neighbouring dwellings. Additional materials for finer detailing should be carefully chosen. Materials used for roofing and walls should match or positively respond to the host dwelling and to the adjacent dwellings, as should materials and colours for doors and window frames. When the materials are chosen well, they will complement the building and the street scene.

## Boundary Treatment

- 6.7 Where existing plot boundaries form a distinctive part of the street scene, these boundaries must be retained and replicated through appropriate building design and landscape treatment. In most cases it will be necessary to consider screening the boundaries of a new development for privacy reasons and to reduce noise and disturbance. Brick walls have better noise attenuation qualities than fences or hedges and will be most appropriate where possible sources of noise would be close to

an existing house, or the garden area immediately outside it.

**Sketch 4** below shows an unacceptable boundary treatment for an infill development.

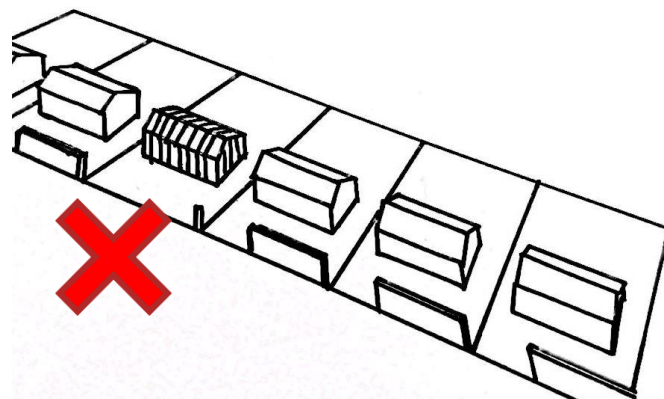

## Corner Sites

- 6.8 Sometimes, it may be appropriate to design slightly taller buildings where they make a positive contribution to the street scene, on primary routes, and in higher density areas with variations in height and massing. Where a taller building is proposed, the end treatment should relate sensitively to the heights of the adjacent buildings so that the rhythm of the street is not interrupted; this will often result in an appropriate reduction of height, maintaining a visual hierarchy on the street scene.

## Detailed Consideration C – Privacy/Amenity

### Privacy/Amenity

7.1 The key considerations relating to privacy and amenity for small scale infill residential development are:

- a. whether the plot would have adequate privacy to habitable rooms and private garden space
- b. whether a new house(s) on the plot would affect the privacy of neighbours
- c. whether a new house(s) on the plot would affect the host dwelling

7.2 Hedges and fences usually protect privacy at ground floor level, so the issues tend to arise from upstairs windows either looking into neighbours' windows or into their neighbours' private garden space. Windows must be carefully positioned to avoid overlooking. Often this means putting obscured glazing in landing or bathroom windows on the side elevation of the house, with the main bedroom windows on the front and rear elevation. However, the positioning of the windows will also depend on the positioning of the neighbouring properties.

### Site Topography

7.3 As well as maintaining the hierarchy of building heights along the streetscene, all proposals need to provide sufficient gaps to minimise any overbearing and overshadowing impact on the residential amenity of neighbouring properties.

### Distances between Dwellings

7.4 As far as the effect of the new dwelling is concerned, the Council's normal privacy standard for new development is that there

should be minimum of 21m between directly facing elevations containing main habitable windows (i.e. bedrooms and living rooms). This distance may be relaxed where windows are facing a public highway.

7.5 Back to back distances should have regard to the character of an area. In some cases, the requirement for minimum back to back distances may be relaxed where the impact on privacy can be reduced. This may be achieved, for example, through the use of obscure glazing and restricted openings, the siting of habitable rooms within an internal floor layout, directional windows, the positioning of ancillary outbuildings. However, it is not acceptable for a habitable room to only have windows which are obscure glazed. Provided that it could be demonstrated that there would be no material harm to amenity, then shorter distances than those stated above could be considered in those inner urban areas typified by higher densities.

7.6 Similarly, greater distances may be required in some suburban and rural areas where the predominant character of the area exhibits greater separation distances. Distances may vary where this is necessary to protect the historic interest and setting of designated heritage assets such as listed buildings and conservation areas.

**Sketch 5** below illustrates that the back to back separation distance should be at least 21m.

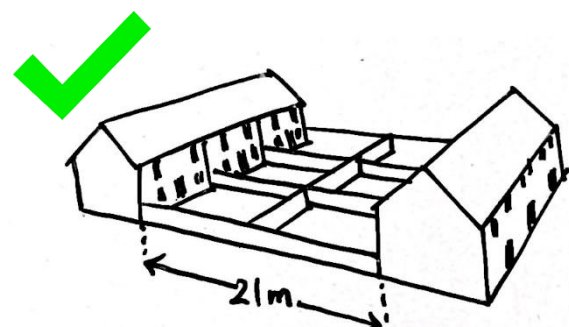

7.7 New buildings near to plot boundaries can be intrusive when viewed from existing gardens or from within dwellings. To avoid over-dominant development and overshadowing of neighbouring properties, there must be at least 15m between principal elevations with main habitable windows and side gable walls without windows (unless these are minor windows such as the landing, WC or utility room windows, or the gable wall in question is single storey). This is applicable to the new dwelling as well as the existing dwelling. This will ensure adequate amenity is provided for future occupiers as well as the existing residents. A reduced distance may be acceptable where the landform between the dwellings and boundary treatments provide acceptable screening.

**Sketch 6** below illustrates that the back to side separation distance should be at least 15m.

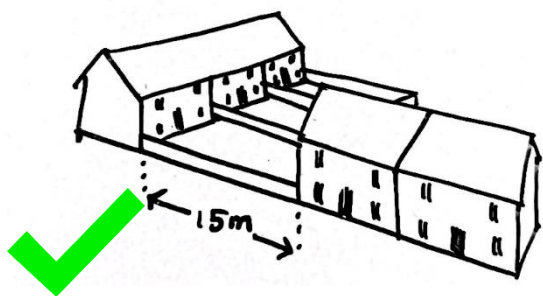

### Distance from the rear and side boundary of the neighbours

7.8 Consideration should also be given to the impact a proposal will have on a neighbour's private garden. Unacceptable direct overlooking into these spaces can be avoided by ensuring a separation distance of at least 10m exists between a proposed first floor habitable room window and the opposite garden boundary of neighbouring properties.

**Sketch 7** below illustrates the 10m (minimum) distance from the first floor rear windows of the proposal to the side boundary of the neighbour.

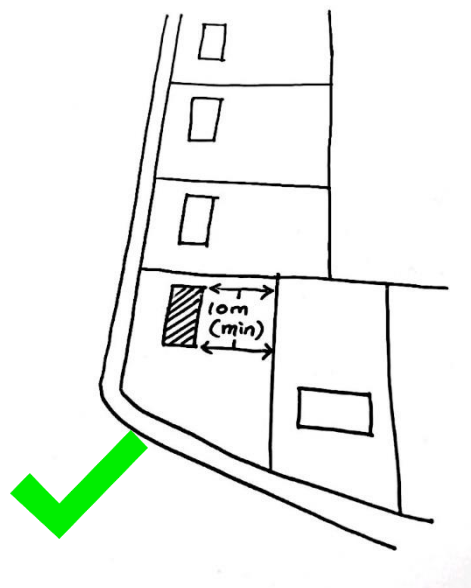

### Carriageway Screening

7.9 Care will need to be taken to ensure that screening would prevent light intrusion from the movement vehicles as a result of the infill development.

## Natural Light and Outlook

- 7.10 Direct sunlight makes a home more pleasant to live in. Dwellings should have access to sufficient daylight to allow the comfortable use of habitable rooms (living rooms, dining rooms and bedrooms), as well as kitchens and outside space such as patio areas in gardens.
- 7.11 Quantitative standards cannot be applied to every case to assess the amount of daylight and sunlight of individual properties and the impact on outlook. Nevertheless, there are several 'rules of thumb' which will inform the judgement to be made. One is the '25° rule' for windows facing other structures. A reference line is taken at 2m above ground level on the existing building. This is the assumed position of the top of ground floor windows in the existing building. A 25° line is then drawn towards the proposed building. If the proposed development falls beneath the line drawn at 25°, there is unlikely to be a detrimental effect to daylight on the existing property.

**Sketch 8** below shows the proposed dwelling crosses the 25° rule for natural light and would not be acceptable.

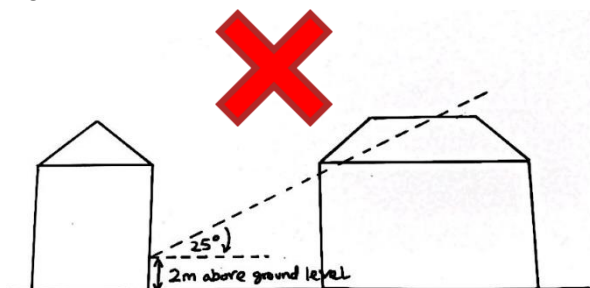

- 7.12 Another assessment to protect daylight and outlook from main living area windows is by operating a 45° splayline (assessed in a plan) from the centre of the relevant window of the existing dwelling of the

adjacent infill development (as shown in Sketch 9). This assessment relates to any proposed two storey development from an existing building line, and windows affected by this proposed two storey development. Any part of the new two storey development which extends beyond the splayline may be considered to adversely affect the amenity of the neighbouring occupiers. The Council will not support any new development that would result in the significant loss of sunlight for existing properties, where it leads to overshadowing for the majority of the day.

**Sketch 9** below shows that a proposed infill development along with its two storey extension crosses the 45° splayline rule and would not be acceptable.

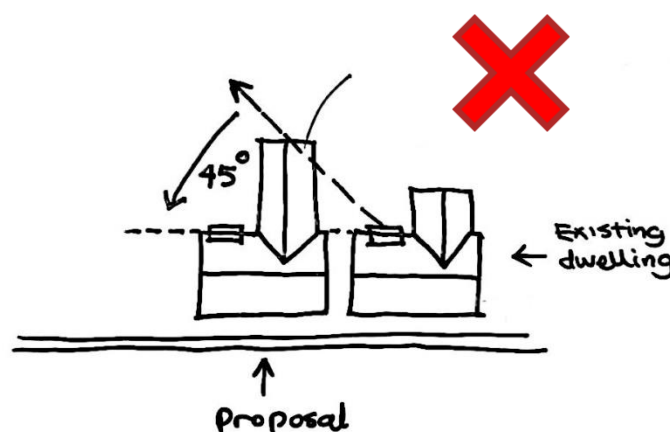

- 7.13 Developments which do not meet these standards (the 25° rule and 45° splayline) will be resisted unless other reasonable measures being proposed to provide adequate light. It is also recognised that the changes to permitted development rights have allowed certain types of development which might exceed these standards. Where proposed development requires planning permission, we will apply this SPG's standards in a reasonable manner.



**Sustainable Transport**

- 8.1 One of the overarching objectives for infill development is to use land more efficiently and to enable development in areas that have easy access to existing amenities by sustainable transport options (i.e. walking, cycling and public transport), thus reducing the need to use private cars.
- 8.2 Reflecting sustainable transport considerations, the Council is keen to see secured cycle parking provision provided within infill plots to encourage/facilitate travel by non-car modes.

**Access widths**

- 8.3 An access drive serving one dwelling should be a minimum of 2.75m wide. If the access drive is longer than 45m, it should be a minimum of 3.7m wide over its whole length to allow for access for service vehicles such as fire engines. For sites of 2 to 5 dwellings minimum width of 4.25m is required, for at least the first 5m – then reducing to 3.7m. A minimum width of 4.8m is required for drives serving more than 5 dwellings.

**Table 4: Minimum Access Widths**

<b>Proposal</b>	<b>Access width in Metres(Minimum)</b>
1 house	2.75m
1 house if the access is greater than 45metres in length	3.7m
2—5 houses	4.25m
Greater than 5 houses	4.8m

- 8.4 In some circumstances, such as to allow trees or other important features to be retained, it may be acceptable to allow a narrowing of a 4.25m access to 3.7m, although such accesses need to be at their full width for the first 10m from the highway to allow vehicles to pull off the road and to pass. All drives should normally allow vehicles to turn and leave the site in a forward direction and drives in excess of 25m will need to make provision for the turning of service vehicles, in terms of both layout and construction. In most cases, and certainly where an access is bounded by solid walls fences, hedges or a line of trees, a 0.5m overhang strip either side of the drive surface should be provided to ease the flow of vehicles.

## **Footway**

- 8.5 All accesses across a footway need to accommodate 2m x 2m pedestrian visibility splays for the safety of pedestrians. Vehicular visibility splays will depend on the speed of traffic on the highway. Please refer to Manual for Streets 2 for further information (Table 6 refers).

## **Parking Spaces and Turning Provision**

- 8.6 On-site parking is normally required to be provided in the plot, in a similar manner to the host property or the adjacent houses. On-site parking should be positioned close to the dwelling and must not be located so as to interfere with any joint access road. Any proposed garage or parking provision must not be overly dominating in the street and matching materials should be used to respect the existing character of the area. Please note that the Council seeks the use of permeable materials for all hardstanding for parking and turning purposes. Please contact the Council's Highways Department for their parking requirements for your proposal.

## **Visibility Splays**

- 8.7 Visibility Splays are an essential feature of an access or junction as they enable traffic a minor road to view cyclists, vehicles and pedestrians on the main road. Any visibility splay below the required standard would need to be justified via appropriate traffic survey. Development proposals should demonstrate the best achievable visibility splay. The splay should be entirely within the applicant's ownership and control and remain so in perpetuity.

## **Hard Surfaces**

- 8.8 It will normally be necessary to provide a hard surface for the first 5m of a new access to prevent loose material being deposited on the highway, although other amenity considerations might require more of the access to be surfaced in a hard material to reduce noise, or in a softer material to respect the character of the site. New accesses will need to be constructed so as to prevent drainage onto the public highway. Where a new carriageway passes close to an existing dwelling it should be hard surfaced to reduce the noise of vehicles.

## **Distances between Access Drives**

- 8.9 In most instances it is important to ensure that any new property or group of properties share a single access point to avoid multiple points of conflict for vehicular movements.

## **Distance to the Carriageway**

- 8.10 The carriageway of a new access serving a Backland Site should be a minimum of 2m from any elevation of an existing property (including a garage to that property). Where any elevation of an existing dwelling with a window would face onto a new carriageway, a new screening should generally take the form of walls for the whole length of the elevation being protected and should include an additional length at the rear to protect any garden immediately outside any main living room, subject to the prevailing character of the site.

### Planting/Trees

- 9.1 Planting is integral to achieving quality residential environments, and should be considered at the outset of the design process. Applicants will be encouraged to plant new native trees in their proposals, even where there is to be no loss of existing trees. The Council will resist any application for development which will result in the loss of trees protected by a Tree Preservation Order, mature trees, hedges and boundary walls which make a positive contribution to a site or the surrounding area. Trees in conservation areas are protected in a similar way to those covered by a Tree Preservation Order and special permission is needed to lop, prune or fell them and to carry out building or ground works within an area covered by the spread of the branches.
- 9.2 New development will not normally be allowed where a building would be situated within the spread of a tree that is worthy of retention. If in doubt, a qualified **arboriculturalist** will be able to carry out a tree survey to determine which trees are worthy of retention, and which trees could be removed due to poor health. Impermeable surfaces should be avoided below the canopy/crown spread of any tree.

### Ecology

- 9.3 Certain species such as bats are legally protected by Law. Many species of bat make use of existing buildings, trees, hedgerows and overgrown sites. This is why it is advised that a **Preliminary Ecological Assessment (PEA)** is undertaken prior to the submission of a planning application so that any mitigation can be integrated into your scheme. The LPA is unable to register a planning application in the absence of adequate protected species information, where relevant. In addition, the LPA will refuse consent in situations where either it cannot be shown that an appropriate licence would be forthcoming from Natural Resources Wales, or where the adverse impacts to a protected species cannot be acceptably mitigated.



## Detailed Consideration F – Drainage

### Foul Drainage

- 10.1 All development should make satisfactory arrangements for foul drainage. A sequential approach should be taken to the consideration of foul drainage options. This should be based on the demonstrable feasibility or otherwise of alternative arrangements, taking into account their cost and/or practicability:
- as a first priority connection should be made to public sewerage infrastructure;
  - where this is not feasible, as a second priority the use of a package sewage treatment plant offering full treatment to recognised standards may be proposed. Proposals should include full details of means of operation and maintenance;
  - only where the above options are not feasible should the use of septic tank systems be proposed.
- 10.2 Any such proposals should include a full assessment of the scheme having regard to the effects on public health, amenity and the environment, and addressing any evidence in respect of Table 5. Where significant adverse environmental, amenity or public health effects are likely to arise through either permanent or temporary use of septic tank drainage, the development concerned will not be permitted. The latest Welsh Government advice is available here: <https://gov.wales/topics/planning/policy/circulars/welshgovcirculars/wgc-008-2018/?lang=en>
- 10.3 Development dependent upon cesspool drainage arrangements will rarely be

permitted and the use of a sustainable foul drainage system will be considered as an alternative to the provisions of this SPG, only where the particular treatment proposal has the approval of the Natural Resources Wales.

### Sustainable Drainage Systems (SuDS)

- 10.4 Schedule 3 of the Flood and Water Management Act 2010 makes SuDS a mandatory requirement for all new developments. The legislation will ensure resilient drainage systems for new developments in both urban and rural areas. From the 7th January 2019, all new developments of more than 1 dwelling will require sustainable drainage systems (SuDS) for managing surface water. All drainage systems for all new developments must be designed and built in accordance with statutory SuDS standards. Please note that SuDS schemes must be approved by Monmouthshire County Council acting in its SuDS Approving Body (SAB) role before construction work begins. As such, this element should be an integral part of your scheme right from the start. For more information, please email [sab@monmouthshire.gov.uk](mailto:sab@monmouthshire.gov.uk).

#### Table 5: Factors Forming a Full Assessment of the Use of a Septic Tank.

- 
- contravention of recognised practices
  - adverse effect on water sources or resources
  - health hazard or nuisance likely to arise
  - damage to controlled waters
  - damage to the environment and amenity
  - overloading of the existing capacity of the area
  - absence of suitable outlets
  - unsuitable soakage characteristics
  - high water table
  - rising ground water levels
  - flooding
-

### Planning Contributions

- 11.1 Depending of the size and nature of the proposal, planning permission is sometimes granted subject to the signing of a planning contributions agreement under Section 106 of the Planning Act. Where applicable, the Section 106 agreement must be signed before the planning permission will be issued.
- 11.2 The Section 106 is a legal charge on the land, so it will transfer automatically with any subsequent change in ownership. Some of the most frequently requested planning obligations include:
- Affordable housing contributions
  - Recreation contributions
  - Transport/highways contributions
  - Education contributions
- 11.3 You can find out via our Pre-Application Advice service if planning obligations are likely to be required in relation to your proposal. Seeking such advice will help you to determine whether your scheme is financially viable.

### Affordable Housing

- 11.4 Policy S4 (Affordable Housing) of the adopted Monmouthshire Local Development Plan and the Council's Affordable Housing Supplementary Planning Guidance sets out the criteria for the provision of affordable housing as part of new residential development schemes. More information can be found using the following link:  
<https://www.monmouthshire.gov.uk/app/uploads/2016/10/Adopted-Affordable-Housing-SPG-March-2016.pdf>.
- 11.5 The plot purchase/sale price should reflect this policy requirement. Viability debates will only be considered in exceptional circumstances, and the applicant will need to robustly demonstrate their case via independent consideration by the District Valuation Service at their own expense.

## 5 Pre-Application Advice and Further Information

**Can I get advice from a Planning Officer before drawing up the plans or applying for a planning permission for small scale infill development?**

- 12.1 We welcome discussions with prospective applicants prior to planning applications being made. Obtaining the right advice in the early stages of your scheme is very important and will help steer your scheme in the right direction from the start. This service gives you the opportunity to explore your scheme with us and find out what kind of information you need to accompany your planning application. In addition, we can discuss possible planning issues that may affect you gaining planning permission. For further information, please refer to our pre-application advice guidance documents: <http://www.monmouthshire.gov.uk/planning/pre-application-advice-service>

**Contact:**

Development Management Service

**Tel:** 01633 644880

**Email:** [planning@monmouthshire.gov.uk](mailto:planning@monmouthshire.gov.uk)

**Post:** Development Management Service,  
County Hall, The Rhadyr, Usk, NP15 1GA

### Table 6: Useful References

- **Monmouthshire Local Development Plan (LDP):**  
<https://www.monmouthshire.gov.uk/app/uploads/2017/05/Adopted-Local-Development-Plan-with-PDF-tags.pdf>
- **Affordable Housing SPG:**  
<https://www.monmouthshire.gov.uk/app/uploads/2016/10/Adopted-Affordable-Housing-SPG-March-2016.pdf>
- **Green Infrastructure SPG:**  
<https://www.monmouthshire.gov.uk/app/uploads/2015/07/GI-April-2015.pdf>
- **Monmouthshire Parking Standards SPG:**  
<https://www.monmouthshire.gov.uk/app/uploads/2015/07/Mon-CC-Parking-Standards-SPG-Jan-2013.pdf>
- **Domestic Garage SPG:**  
<https://www.monmouthshire.gov.uk/app/uploads/2015/07/Domestic-Garage-SPG-Jan-2013.pdf>
- **Conservation Areas Appraisals:**  
<https://www.monmouthshire.gov.uk/planning-policy/conservation-area-appraisals>
- **Planning Policy Wales 10 (PPW10):**  
<https://beta.gov.wales/planning-policy-wales>
- **Technical Advice Notes (TAN):**  
<https://gov.wales/topics/planning/policy/tans/?lang=en>
- **Manual for Streets 2:**  
<https://www.gov.uk/government/publications/manual-for-streets-2>
- **Planning (Listed Buildings and Conservation Areas) Act 1990:**  
<https://www.legislation.gov.uk/ukpga/1990/9/contents>
- **Welsh Government Circular 008/2018 (Private Sewerage):**  
<https://gov.wales/topics/planning/policy/circulars/welshgovcirculares/wgc-008-2018/?lang=en>
- **Sustainable drainage systems (SuDs):**  
<https://www.monmouthshire.gov.uk/sustainable-drainage-approving-body-sab>

## **Appendix A**

### **Monmouthshire LDP Policy Framework Policies S1, H1, H2 and H3**

## Policy S1 – The Spatial Distribution of New Housing Provision

The main focus for new housing development is within or adjoining the Main Towns of:

- Abergavenny, Chepstow and Monmouth.

The Severnside sub-region consists of the settlements of Caerwent, Caldicot, Magor, Portskewett, Rogiet, Sudbrook and Undy. A smaller amount of new housing development is provided in the Severnside sub-region, particularly at Magor/Undy, Caldicot/Portskewett and Sudbrook.

The Rural Secondary Settlements are Usk, Raglan, Penperlleni and Llanfoist. A small amount of new housing development is directed to the Rural Secondary Settlements of Usk, Raglan and Penperlleni

Some sites are allocated for small scale residential development (up to a maximum of 15 dwellings) in identified Main Villages with the primary aim of providing affordable housing to meet local needs. The identified Main Villages are:

Cross Ash	Llanishen
Devauden	Llanvair Kilgeddin
Dingestow	Mathern
Grosmont	Penallt
Little Mill	Pwllmeyric
Llanddewi Rhydderch	Shirenewton /Mynyddbach
Llandogo	St Arvans
Llanellen	Trellech
Llangybi	Werngifford /Pandy

Development Boundaries are drawn around the Main Towns, Severnside settlements, Rural Secondary Settlements and Main Villages listed above. Outside these development boundaries planning permission for new residential development will not be allowed in any other settlements except in or adjoining identified Minor Villages where small scale residential development will be allowed in the circumstances set out in Policy H3. The identified Minor Villages are:

Bettws Newydd	Llanover
Broadstone/Catbrook	Llansoy
Brynygwenin	Llantilio Crossenny
Coed-y-Paen	Llantrisant
Crick	Llanvair Discoed
Cuckoo's Row	Llanvapley

(S1 continued...)

Great Oak	Mitchel Troy
Gwehelog	Penpergwm
Llanarth	The Narth
Llandegveth	The Bryn
Llandenny	Tintern
Llangwm	Tredunnock

Outside the settlements listed above open countryside policies will apply where planning permission will only be allowed for the following types of new residential development:

- Acceptable conversions of rural buildings, in the circumstances set out in Policy H4.
- Sub-divisions of existing dwellings, subject to detailed planning criteria.
- Dwellings necessary for agricultural, forestry or other appropriate rural enterprises, in accordance with TAN6.

#### **Policy H1 – Residential Development in Main Towns, Severnside Settlements and Rural Secondary Settlements.**

**Development boundaries have been drawn for the Main Towns, Severnside Settlements and Rural Secondary Settlements identified in Policy S1, within which new build residential development / redevelopment or conversion to residential, or subdivision of large dwellings or reuse of accommodation such as upper vacant floors in town centres will be permitted subject to detailed planning considerations and other policies of the LDP that seek to protect existing retail, employment and community uses.**

### **Policy H2 – Residential Development in Main Villages**

Development boundaries have been drawn for the Main Villages identified in Policy S1. These development boundaries include sites identified for new rural housing that are listed in Allocations Policy SAH11.

Elsewhere within the Village Development Boundaries planning permission will be granted for new residential development/redevelopment, or conversion to residential, or sub-division of large dwellings, subject to detailed planning considerations, including no unacceptable adverse impact on village form and character and surrounding landscape, and other policies of the LDP that seek to protect existing retail, employment and community uses.

### **Policy H3 – Residential Development in Minor Villages**

In Minor Villages planning permission will be granted for minor infill of no more than 1 or 2 dwellings resulting from the filling in of a small gap between existing dwellings, or residential redevelopment, or conversion to residential or sub-division of large dwellings, subject to detailed planning considerations, including no unacceptable adverse impact on village form and character and surrounding landscape, and other policies of the LDP that seek to protect existing retail, employment and community uses.

Exceptionally planning permission may be granted for up to 4 dwellings on an infill site that demonstrably fits in with village form (including not resulting in the loss of an open space that forms an important gap or open area) and is not prominent in the landscape.